



**DOWNTOWN DEVELOPMENT AUTHORITY
BOARD OF DIRECTORS REGULAR MEETING
WEDNESDAY, JANUARY 24, 2024 – 3:00 P.M.**

BOARD MEMBERS PRESENT: Ehrlich Crain (3:01)
Charles Beckham
David Blaszkiewicz (3:01)
John Naglick
Hassan Beydoun
James Jenkins
Steve Ogden
Melvin Hollowell

BOARD MEMBERS ABSENT: Marvin Beatty
Austin Black
Richard Hosey

OTHERS PRESENT: Kenyetta Bridges (DEGC/DDA)
Rebecca Navin (DEGC/DDA)
Maxwell Cameron (DEGC/DDA)
Jennifer Kanalos (DEGC/DDA)
Glen Long (DEGC/DDA)
Nasri Sobh (DEGC/DDA)
Sierra Spencer (DEGC/DDA)
Kevin Johnson (DEGC/DDA)
Lanard Ingram (DEGC/DDA)
Annalise Frank (Axios Detroit)



**MINUTES OF THE DOWNTOWN DEVELOPMENT AUTHORITY
BOARD OF DIRECTORS REGULAR MEETING
DETROIT ECONOMIC GROWTH CORPORATION
500 GRISWOLD, SUITE 2200, DETROIT, MI 48226
WEDNESDAY, JANUARY 24, 2024 – 3:00 P.M.**

GENERAL

Call to Order

Chairperson Beydoun called the regular meeting of the Downtown Development Authority Board of Directors to order at 3:00 p.m. Roll call was conducted, and a quorum was established.

GENERAL

Approval of Minutes

Mr. Beydoun asked if there were any additions, deletions, or corrections to the minutes of the January 10, 2024, Regular Board meeting. Hearing none, the Board took the following action:

Mr. Beckham made a motion approving the January 10, 2024 minutes, as written. Mr. Hollowell seconded the motion. All were in favor with none opposed.

DDA Resolution Code 24-01-02-660 was unanimously approved.

PROJECTS

**LOWER WOODWARD IMPROVEMENT AGENDA PARKING LOT BEAUTIFICATION
PROJECT: AUTHORIZATION TO ENTER INTO CONTRACT WITH INDUSTRIAL FENCE AND
LANDSCAPING INC.**

Mr. Cameron stated that in anticipation of the Spring 2024 NFL Draft scheduled to take place in downtown Detroit, the City's administration has requested the DDA's assistance in connection with various planned public improvement and beautification initiatives throughout the DDA Downtown Development Area 1. The 2024 NFL Draft is scheduled to take place April 25-27, 2024, and is expected to attract approximately 500,000 visitors downtown.

In June 2023 and January 2024, the DDA Board approved, among other items, the DDA's management of the Parking Lot Beautification Project (the "Project"). Parking lots that have obtained BSEED compliance are eligible to participate in the Project which includes the provision of matching grants for beautification measures as specified by City's Planning and Development Department.

To solicit proposals for the Project, DDA staff issued a request for proposals on November 1, 2023, that was published in print and online at BidNet (the "RFP").



This RFP was related to fencing and bollard components of the beautification project. All bidders were asked to provide a bid to perform the following work (collectively, the “Work”):

- Installation of fencing or bollards per PD&D site recommendations, including removal of any existing fencing or barriers.
- Complete identified repairs to existing fencing and/or bollards per PD&D site recommendations.

Following DDA’s solicitation for bids, DDA received bids from five (5) contractors and conducted post-bid interviews with selected bidders. Prior to evaluating the bids received, DDA staff applied an equalization credit to Detroit-headquartered and Detroit-based businesses. The five (5) bids received, adjusted for the equalization credit, and the score given to each bid are as follows:

Bidder	Location	Base Bid Price	Equalization Credit	Adjusted Base Bid Price	Score
Industrial Fencing	Detroit, MI	\$602,312.00	6%	\$566,173.28	1.4
Decima	Detroit, MI	\$436,280.00	6%	\$410,103.20	1.8
DMC	Detroit, MI	\$614,135.00	6%	\$577,286.90	2.15
PGA	Detroit, MI	\$835,171.00	6%	\$785,060.74	2.2
Nationwide Construction Group	Richmond, MI	\$1,880,486.00	0%	1,880,486.00	2.6

DDA staff evaluated and scored the bids to determine that Industrial Fencing and Landscaping, INC (the “Contractor”) was the most responsive bidder for the following reasons:

- The Contractor’s proposal was the second lowest-scored proposal upon application of the equalization credit and scoring. However, following our review of the proposals and interviews with the contractors, we believe that their pricing most accurately reflected the required scope of work;
- The Contractor has a history of completing projects of similar scope and scale;
- The Contractor has completed previous work with the DDA and other DEGC-related entities to the satisfaction of DDA staff;
- The Contractor has the ability perform the Work on the schedule presented to it by DDA staff.

DDA Staff is requesting the DDA board authorize the execution of a contract with the Contractor to perform the Work at the not to exceed amount of Six Hundred Two Thousand Three Hundred Twelve and 00/100 (\$602,312.00) Dollars.



DDA staff is also recommending that a contingency representing ten (10%) percent of the total value of the Work, or Sixty Thousand Two Hundred Thirty One and 20/100 (\$60,231.20) Dollars be established to be disbursed upon the authorization of authorized DDA staff.

A resolution approving and authorizing the DDA to enter into a contract with the Contractor for the performance of the Work and the establishment of a contingency fund was attached for the Board's review and consideration.

Mr. Naglick asked if the vendor for the bollards is Detroit-based. Mr. Cameron responded that the vendor is called Ideal, and they are based in Southwest Detroit.

Mr. Jenkins stated that he is familiar with the company Industrial Fencing and noted this is a well-known company. Mr. Jenkins asked if the contract was a lump sum bid or a not to exceed amount. Mr. Cameron explained that the bids were put on a per-site basis, meaning that the total contract amount is the total of every potential site for the project. Mr. Jenkins asked if the actual price could be lower than what is being presented or if the number was a lump sum contract. Ms. Navin explained that the price is on a time and material basis, meaning that if fewer sites participate than what was bid out, the final price will reflect that and be reduced.

Mr. Beydoun referenced the map provided to the Board and asked if the maximum amount written accounts for the 10 sites that are pending agreements. Mr. Cameron stated that this is the most updated map related to the project, and the 10 pending sites were based on the prior program scope. Mr. Cameron added that since the scope has changed 20 more sites have joined the program.

Mr. Jenkins stated that he appreciated the materials given to the Board regarding the project being discussed because the Board had asked for a site plan map previously and it allows for clear representation of the affected areas. Mr. Jenkins asked if all the sites were public parking lots. Mr. Cameron responded that to be eligible for the program lots must be in compliance and be open to the public.

Mr. Ogden asked for clarification on what EDIS referred to. Mr. Cameron explained that EDIS or Economic Development Investment Services is a team within the DEGC led by Kenyetta Bridges that completes work on several economic development projects.

Mr. Ogden called attention to the 5 bidders outlined in the Board materials noting that he followed this piece, but the scoring matrix is not self-explanatory, and asked for a short explanation of how the bids were scored. Mr. Ogden suggested that in the future if an explanation is not given for the scores, that the scores not be included. Mr. Cameron stated that the scores are based on several factors including the price of the bid proposal, prior experience, and their status of being Detroit-based. Mr. Ogden stated that he was happy that these things are being done, as they have historically been done in the past but stated his point was the scores are not intuitive. Mr. Ogden thanked Ms. Bridges for leading the EDIS team.

Mr. Crain called attention to the information located under the pricing grid in the Board's materials, as it spells out the basis of the scoring.



Mr. Jenkins asked if when there is a not-to-exceed contract from this point on that unit price is always involved. Mr. Cameron agreed.

Mr. Beydoun called for further discussion. Hearing none, he called for a motion.

Mr. Crain made a motion approving the Lower Woodward Improvement Agenda Parking Lot Beautification Project: Authorization to Enter into Contract with Industrial Fence and Landscaping Inc, as presented. Mr. Blaszkievicz seconded the motion. All were in favor, none opposed.

DDA Resolution Code 24-01-101-172 was unanimously approved.

CAMPUS MARTIUS PROJECT: KENNEDY GARAGE INSTALLATION OF EV CHARGER STATIONS

Mr. Cameron stated that as the Board may recall, the City of Detroit Downtown Development Authority (“DDA”) has entered into a Master Lease Agreement (as amended, the “Lease”) with Kennedy Square Garage, LLC, an affiliate of REDICO (“REDICO”), to lease the Kennedy Square parking facility (the “Kennedy Garage”) in connection with operation of the One Kennedy Square office building. Pursuant to Section 8 of the Lease, REDICO must seek DDA consent prior to the making of any alterations, additions or improvements to the Garage.

REDICO has requested the approval of the installation of Electric Vehicle (EV) charger stations to be located in Kennedy Garage. The scope of work for this project includes the following:

- Installation of two (2) dual port charging stations on the P1 level of the garage.
- Electrical infrastructure upgrades that will have the capacity to support eight (8) dual port charging stations. This includes the two (2) proposed stations and capacity to add six (6) additional charging locations in the future, subject to further DDA approval.

REDICO has proposed installation of two (2) dual port charging stations to be located adjacent to the electrical room on the P1 level of the garage. These charging stations will be able to accommodate up to four electric vehicles. Additionally, the project will include upgrades to the electrical infrastructure that will provide capacity for the installation of additional EV charging stations in the future. Any additional stations would be subject to DDA Board approval. REDICO will be responsible for all costs, permitting, and the selection of the contractor(s) associated with this project. Furthermore, any costs associated with compliance with permits and/or future or current ordinances and/or other regulations regarding placement of EV charging stations in parking facilities would be REDICO’s responsibility. This could include additional fire suppression systems, inspection costs, and maintenance costs.

Both REDICO and DDA staff have undertaken a number of steps to review the proposed project. REDICO provided DDA staff with electrical drawings, completed by Walbridge which detail the layout and location of the proposed EV charging stations. The annual inspection of the Garage by the Detroit Fire Department’s (DFD) Fire Marshall has also been completed. As of Fire



Marshall's inspection report dated November 3, 2023, the Garage is fully compliant with DFD requirements.

DDA staff have reviewed the plans provided for the proposed chargers. Additionally, staff have sought input from the DFD's Office of Plans and Examinations as far as understanding any fire risks posed by the installation of EV Chargers in the garage. Based on the feedback we have received, DFD's the Plans and Examination office will be responsible for reviewing and signing off on the permit necessary to install the proposed chargers.

DDA Staff are requesting the DDA Board authorize the installation of the proposed EV charging stations and electrical upgrades, subject to final approval from the DFD on the permitting and placement of the proposed charging system.

A resolution approving and authorizing the DDA to modify the project scope was attached for the Board's review and consideration.

Mr. Naglick asked who would be responsible for paying for the electricity under the lease agreement. Mr. Cameron explained that the EV charging station itself has a point of purchase and therefore will collect revenue from individuals utilizing the stations. Mr. Cameron further explained that the electricity cost is covered under the lease with REDICO.

Mr. Long stated that REDICO would cover the cost and receive the benefits from the chargers as well. Mr. Naglick clarified that REDICO would be paying all the costs related to utilities and upkeep of the garage and under the agreement currently before the Board REDICO is to receive the revenue. Mr. Long stated that was correct. Mr. Naglick stated that this is incremental revenue for REDICO but is also probably an incremental expense since they are using electricity to power the stations. Mr. Long stated that the concern is that the fire department sign off on the project, adding that the master lease is long-term.

Mr. Beydoun asked if the proposed EV chargers level 2 or 3 and what reasons were the level chosen. Mr. Cameron explained that the chargers were level 2 but was not sure about REDICO's reasoning for their choice.

Mr. Jenkins stated that he would like to know the reason behind choosing level 2 over level 3. Mr. Jenkins asked if there was a mistake in writing that Wallbridge would complete the electrical drawings because he does not recognize Wallbridge as an electrical contractor. Mr. Cameron stated that he would be willing to go back to REDICO and review the electrical plans provided by them which named Wallbridge in their plans.

Mr. Beydoun called for further discussion. Hearing none, he called for a motion.

Mr. Blaszkiewicz made a motion approving the Campus Martius Project: Kennedy Installation of EV Charger Stations, as presented. Mr. Hollowell seconded the motion. All were in favor, none opposed.

DDA Resolution Code 24-01-105-07 was unanimously approved.

ADMINISTRATIVE



OTHER BUSINESS

PUBLIC COMMENT

None.

ADJOURNMENT

With there being no further business to be brought before the Board, Mr. Beckham made a motion to adjourn, which was seconded by Mr. Jenkins, Mr. Beydoun adjourned the meeting at 3:21 p.m.



CODE DDA 24-01-02-660

APPROVAL OF MINUTES OF JANUARY 10, 2024

RESOLVED that the minutes of the Regular meeting of January 10, 2024, are hereby approved and all actions taken by the Directors present at such meeting, as set forth in such minutes, are hereby in all respects ratified and approved as actions of the Downtown Development Authority.

January 24, 2024



CODE DDA 24-01-101-172

LOWER WOODWARD IMPROVEMENT AGENDA PARKING LOT BEAUTIFICATION PROJECT: AUTHORIZATION TO ENTER INTO CONTRACT WITH INDUSTRIAL FENCE AND LANDSCAPING INC.

WHEREAS, the DDA is being asked to manage the Parking Lot Beautification Project in downtown Detroit, consisting of implementing beautification measures on surface lots including the provision of installation of fencing/bollards, landscaping planters, trash cans art murals, benches, etc; and

WHEREAS, DDA staff received proposals from five (5) contractors to remove, replace and perform the following (collectively, the “Work”):

- Installation of fencing or bollards per PD&D site recommendations, including removal of any existing fencing or barriers.
- Complete identified repairs to existing fencing and/or bollards per PD&D site recommendations; and

WHEREAS, DDA staff have reviewed the quotes and determined that Industrial Fencing and Landscaping, INC. (the “Contractor”) is the lowest, most responsive bidder; and

WHEREAS, DDA staff is requesting the authorization to enter into an agreement with the Contractor for the not-to-exceed amount of Six Hundred Two Thousand Three Hundred Twelve and 00/100 (\$602,312.00) Dollars for the performance of the Work; and

WHEREAS, DDA staff is also recommending that a contingency of approximately ten (10%) percent of the total contract value, Sixty Thousand Two Hundred Thirty One and 20/100 (\$60,231.20) Dollars be established; and

WHEREAS, pursuant to its statutorily authorized powers, the DDA has the power to accept funding, expend DDA funds, engage professionals, and take the other steps contemplated by this Resolution.

NOW, THEREFORE, BE IT RESOLVED, that the DDA Board of Directors hereby authorizes the engagement of the Contractor to perform the Work at the not-to-exceed amount of Six Hundred Two Thousand Three Hundred Twelve and 00/100 (\$602,312.00) Dollars.

BE IT FURTHER RESOLVED, that the DDA Board of Directors hereby authorizes the establishment of a contingency of approximately ten (10%) percent of the total value of the Work, or Sixty Thousand Two Hundred Thirty One and 20/100 (\$60,231.20) Dollars, to be disbursed upon the authorization of any two Officers, or any one of the Officers and any of the Authorized Agents of the DDA, or any two Authorized Agents of the DDA.

BE IT FURTHER RESOLVED, that any one of the officers and any one of the Authorized Agents of the DDA or any two of the Authorized Agents of the DDA shall hereafter have the authority to negotiate and execute all documents, contracts, or other papers, and take such other



actions, necessary or appropriate to implement the provisions and intent of this Resolution on behalf of the DDA.

BE IT FINALLY RESOLVED, that all of the acts and transactions of any officer or authorized agent of the DDA, in the name and on behalf of the DDA, relating to matters contemplated by the foregoing resolutions, which acts would have been approved by the foregoing resolutions except that such acts were taken prior to execution of these resolutions, are hereby in all respects confirmed, approved and ratified.

January 24, 2024

AEGIS II[®]

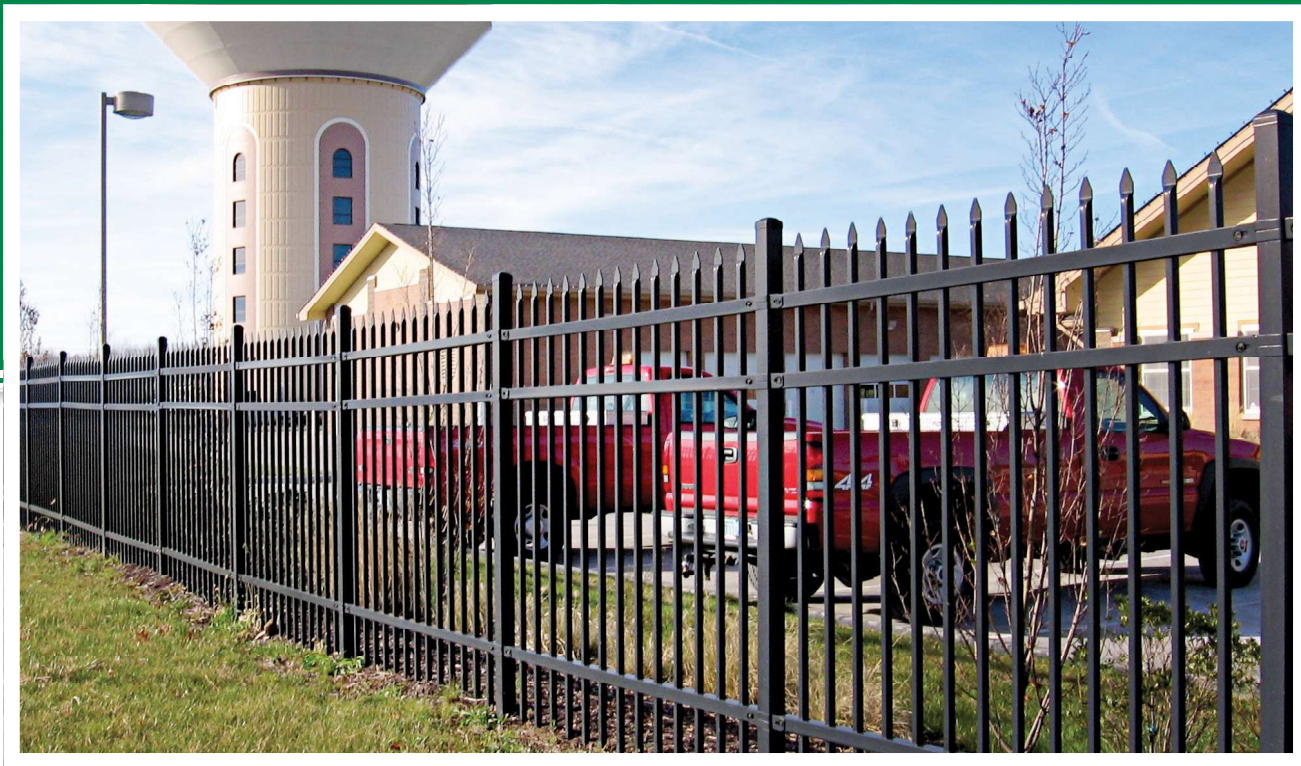

INDUSTRIAL ORNAMENTAL STEEL FENCE

Aegis II is the obvious front-runner in *strength and durability* for fence and gates. With a dual wall ForeRunner rail and *multi-layer coating*, this fence system is unmatched in overall product performance. In addition, the superior component design of Aegis II makes it *easy to customize* for any project application.

PRIMARY APPLICATIONS

- *Stadiums & Event Centers*
- *Schools & Universities*
- *Airports*
- *Water Treatment & Storage*
- *Public Housing Authorities*
- *State Facilities*
- *Municipal Facilities*
- *Parks & Recreation*
- *Hospitals*

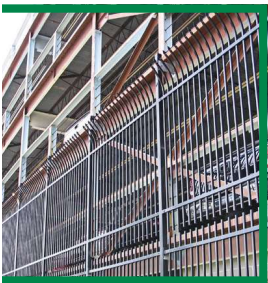

AMERISTARFENCE.COM | 888-333-3422

ASSA ABLOY, the global leader in door opening solutions

AMERISTAR[®]
ASSA ABLOY



PARAMOUNT DECORATIVE BOLLARD COVER

Specifications

- **AVAILABLE IN ANY COLOR:** We can match any color imaginable
- **MADE OF:** 1/4" LDPE plastic with ultra-violet and anti-static additives
- **PATENTED INSTALL:** Covers fit 4" diameter pipe
- **WITH FLARE:** 51" overall height, covers 48" tall pipe
- **WITHOUT FLARE:** 36" overall height, covers 32" tall pipe

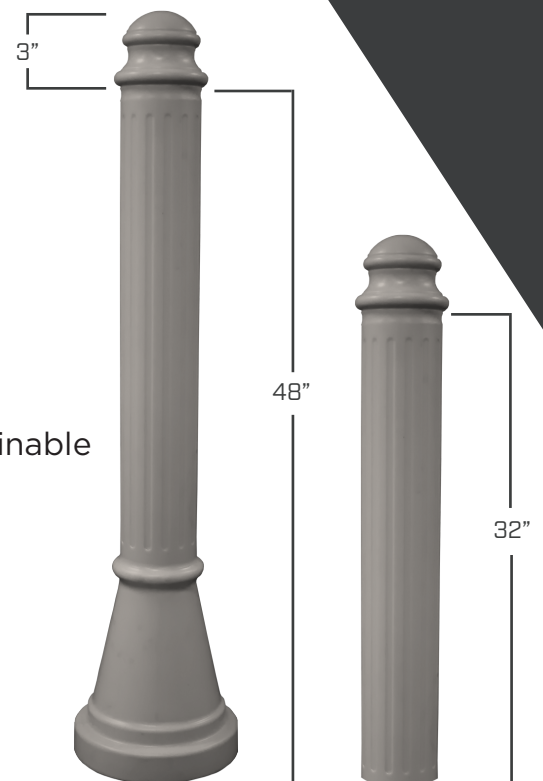

WITH FLARE

W/O FLARE

CONTACT US FOR A QUOTE TODAY
(313) 551-2275



WWW.IDEALSHIELD.COM

NFL DRAFT: SURFACE LOT IMPROVEMENT

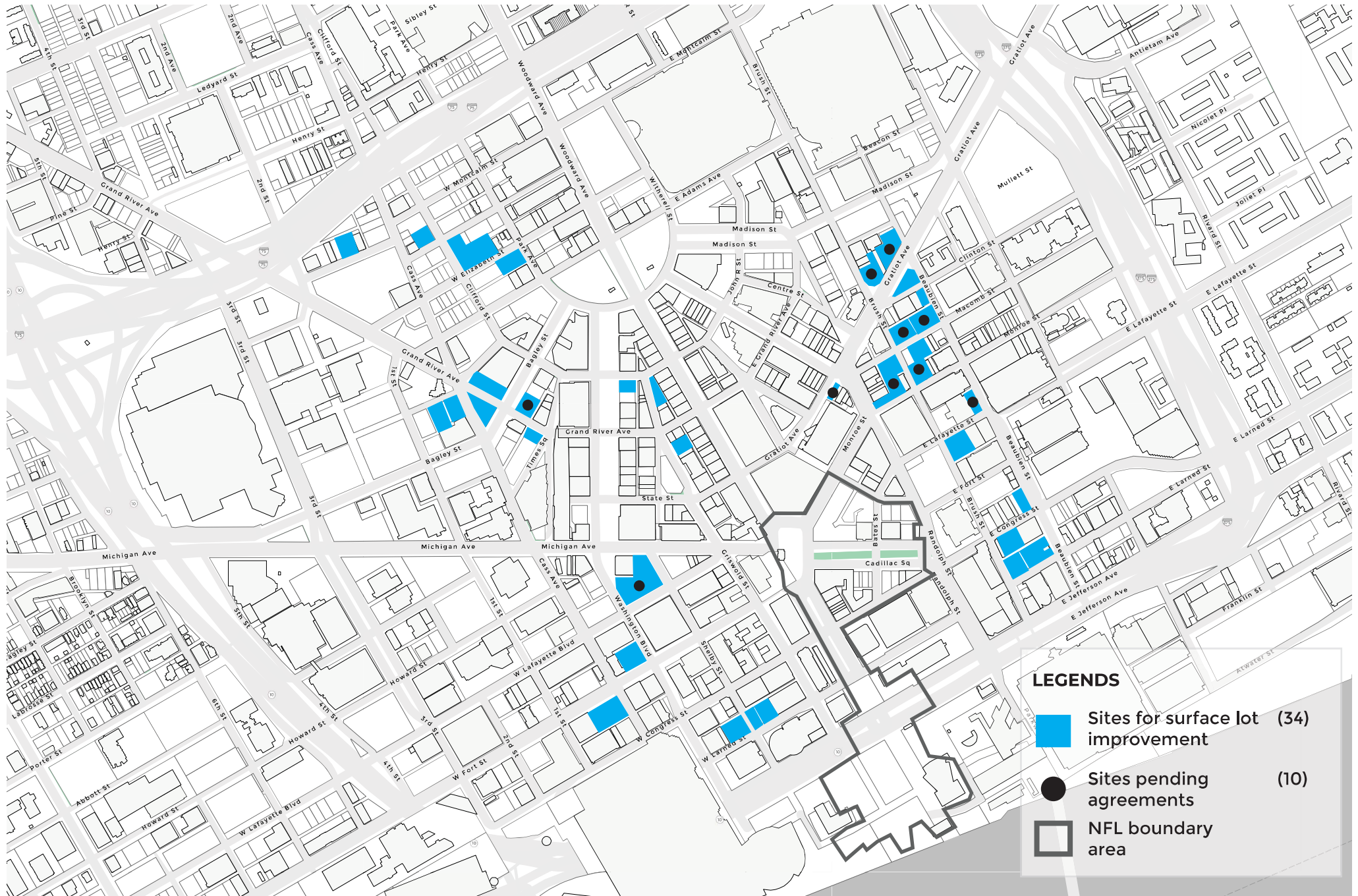



CODE DDA 24-01-105-07

CAMPUS MARTIUS PROJECT: KENNEDY GARAGE INSTALLATION OF EV CHARGER STATIONS

WHEREAS, the City of Detroit Downtown Development Authority (“DDA”) has entered into a Master Lease Agreement (as amended, the “Lease”) with Kennedy Square Garage, LLC, an affiliate of REDICO (“REDICO”), to lease the Kennedy Square parking facility (the “Kennedy Garage”) and pursuant to Section 8 of the Lease, REDICO must seek DDA consent prior to the making of any alterations, additions or improvements to Kennedy Garage; and

WHEREAS, REDICO has requested approval of the installation of Electric Vehicle (EV) charging stations and associated electrical upgrades at the Kennedy Garage; and

WHEREAS, the proposed project includes the following scope of work:

- Installation of two (2) dual port charging stations on the P1 level of the garage.
- Electrical infrastructure upgrades that will have the capacity to support eight (8) dual port charging stations. This includes the two (2) proposed stations and capacity to add six (6) additional charging locations in the future, subject to further DDA approval.

WHEREAS, REDICO has provided electrical drawings, layout, and charger specification for DDA staff review; and

WHEREAS, REDICO will be responsible for all project costs, permitting, and contractor selection to complete the project; and

WHEREAS, DDA staff have reviewed the proposed project, including seeking input on the proposed installation from the Detroit Fire Department’s Office of Plans and Examinations; and

WHEREAS, REDICO will be required to obtain permits from the City of Detroit in order to complete the installation of the proposed EV charging stations; and

WHEREAS, REDICO will be responsible for any costs associated with maintenance and compliance associated with the proposed EV charging system.

WHEREAS, pursuant to its statutorily authorized powers, the DDA has the power to accept funding, expend DDA funds, engage professionals, and take the other steps contemplated by this Resolution.

NOW, THEREFORE, BE IT RESOLVED, that the DDA Board of Directors hereby authorizes the proposed project scope, subject to final approval by the Detroit Fire Department through the required permitting process.

BE IT FURTHER RESOLVED, that any one of the officers and any one of the Authorized Agents of the DDA or any two of the Authorized Agents of the DDA shall hereafter have the authority to negotiate and execute all documents, contracts, or other papers, and take such other



actions, necessary or appropriate to implement the provisions and intent of this Resolution on behalf of the DDA.

BE IT FINALLY RESOLVED, that all of the acts and transactions of any officer or authorized agent of the DDA, in the name and on behalf of the DDA, relating to matters contemplated by the foregoing resolutions, which acts would have been approved by the foregoing resolutions except that such acts were taken prior to execution of these resolutions, are hereby in all respects confirmed, approved and ratified.

January 24, 2024

EV-2
EV-1
EV-3
EV-4

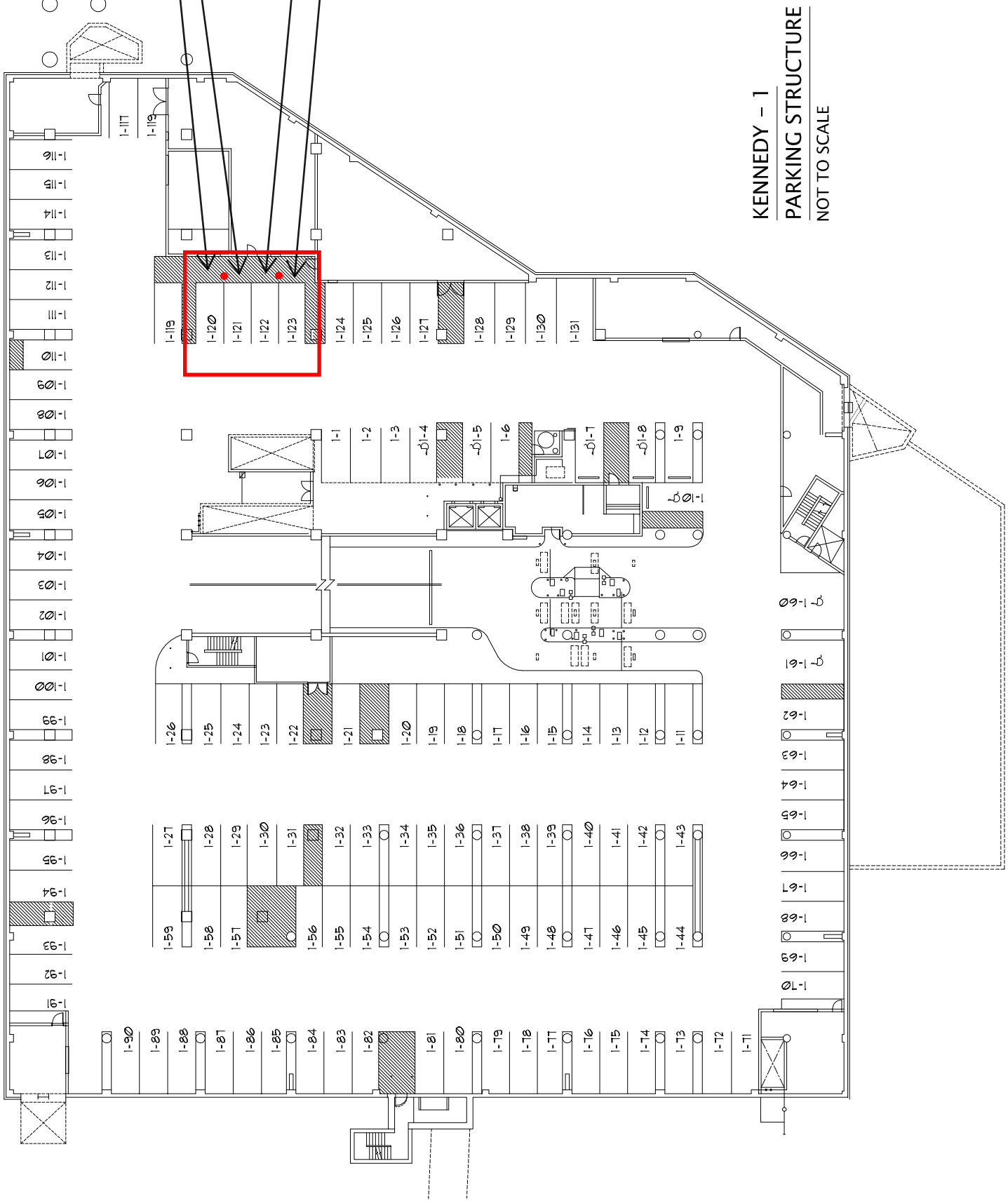

KENNEDY - 1
PARKING STRUCTURE
NOT TO SCALE

FLASH

FLASHPARKING LEVEL 2 EV CHARGING UNIT (DUAL-PEDESTAL)

AC Input

Input Rating Single-Phase: 200~240Vac
AC Input Connection L1/L2/GND or L/N/PE
Input Current 48A
Frequency 50Hz/60Hz
AC Output Output Current 48A
Output Power 11.5kW (240Vac*48A)

User Interface & Control

Display LED Pilot Lamp (standard), 5-inch LCD (Optional)
User Authentication RFID (ISO/IEC 14443A/B, ISO/IEC 15693, FeliCaTM, MIFARE), ISO 15118
Meter Meter IC (1% Accuracy)

Communication

External LAN+WiFi (Standard) or LAN+4G+WiFi (Optional)
Internal OCPP 1.6 JSON (Upgradeable to 2.0) EEBUS (Support in 2022)
Environmental

Operating Temperature -30oC ~ +50oC (-22oF ~ +122oF) Standard
Humidity < 85% (RH) @50oC (+122oF)
Altitude \leq 2000m (6562ft)

Enclosure Protection (IK/IP Level) NEMA TYPE 4
Cooling Method Natural Cooling

Mechanical

Dimension(WxDxH) 295mm x 158mm x 505mm
(11.61in x 6.22in x 19.88in)

Weight <7kg (15.43lbs) with Socket; <10kg (22lbs) With Cable
Cable Length 5m (16.4ft)
7.5m (24.6ft) with Optional Cable Management

Protection

RCD/CCID CCID 20
Input Side UVP, OVP, Surge Protection, Ground Fault
Output Side OCP, Control Pilot Fault, Residual Current Protection
Protocol OTP, Relay Welding Detection, CCID Self-Test, MCU Function Fault Detection
Regulation
Certification UL2594, UL2231-1/-2,
CTEP, EnergyStarTM
Wireless Certification FCC/IC
Charging Interface SAEJ1772 Type 1 Plug



3801 S. Capital of Texas Highway, Suite 250, Austin, TX 78704 | (888)737-7465 | www.flashparking.com

This is a preliminary proposal and does not constitute a binding contract or order.